

**Distributed I/O device in 6 DIN module box
8 digital inputs, 4 relay outputs communicating over RS-485**

DAT 10130

FEATURES

- Modbus Server device on RS-485
- Modbus RTU/ Modbus ASCII protocol
- 8 digital inputs
- 4 relay outputs (2 format SPDT + 2 format SPST)
- Communication parameters configurable by dip-switches
- Watch-Dog Alarm
- Remotely Configurable
- 1500 Vac 3-ways Galvanic Isolation
- LEDs of signalling on front side for power supply and communication
- LEDs of signalling on front side for digital inputs and outputs state
- Connection by removable screw terminals
- High Accuracy
- CE/UKCA mark
- DIN rail mounting in compliance with EN-50022

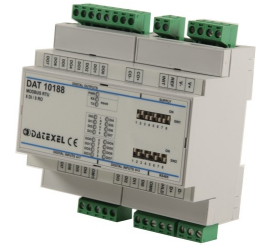

GENERAL DESCRIPTION

The device DAT10130 is able to acquire up to 8 digital inputs with connection NPN or PNP and to drive up to 4 relay outputs of which 2 format SPDT and 2 in format SPST. The data are transmitted with MODBUS RTU / MODBUS ASCII protocol over the RS-485 network.

To ensure the plant safety, a Watch-Dog timer alarm is provided.

The isolation between the parts of circuit removes eventual ground-loop effects, allowing the use of the device even in the heavy environmental conditions.

The device is housed in a 6 module DIN rough self-extinguishing plastic box for mounting on EN-50022 standard DIN rail.

USER INSTRUCTIONS

Before to install the device, please read the "Installation Instruction" section.

It is possible to configure the device in two modes: by the dip-switches located on the front of the device or via software using the INIT modality.

Connect the terminal INIT to the terminal REF; at the power-on the device will be automatically set in the configuration set-up (refer to the User Guide of the device).

Connect power supply, serial bus digital inputs and digital outputs as shown in the "Wiring" section.

The LEDs state depends on the working condition of the device: see the "Light Signalling" section to verify the device working state.

To perform configuration and calibration operations, read the instructions in the User Guide of the device.

To simplify handling or replacing of the device, it is possible to remove the wired terminals even with the device powered.

TECHNICAL SPECIFICATIONS (Typical @ 25 °C and in the nominal conditions)

DIGITAL INPUTS (WET CONTACTS)		SERIAL OUTPUT	GENERAL SPECIFICATIONS
Channels	8	Data Transmission	Power supply voltage 10 .. 30 Vdc
Voltage input (bipolar)		RS-485 asynchronous serial	Reverse polarity protection 60 Vdc max
OFF State	0 ÷ 3 V	Baud Rate	Current consumption @ 24 Vdc
ON State	10 ÷ 30 V	Max. distance	(stand-by) 35 mA
Impedance	4.7 KΩ		(relays operative) 80 mA max
Sample time	5 ms		Max. Current consumption 180 mA
DIGITAL OUTPUTS			ISOLATION
Channels	4		Among all the ways 1500 Vac, 50 Hz, 1 min
Type	N° 2 relay SPDT N° 2 relay SPST		ENVIRONMENTAL CONDITIONS
Maximum Switching Power			Operative temperature -10°C .. +60°C
Resistive load - per contact	2 A @ 250 Vac 2 A @ 30 Vdc		Storage temperature -40°C .. +85°C
Max. voltage	250Vac (50 / 60 Hz) 30Vdc		Humidity (not condensing) 0 .. 90 %
Dielectric strength between contacts	1000 Vac, 50 Hz, 1 min.		Maximum Altitude 2000 m slm
Dielectric strength between coil and contacts	4000 Vac, 50 Hz, 1 min.		Installation Indoor
			Category of Installation II
			Pollution Degree 2
			MECHANICAL SPECIFICATIONS
			Material Self-extinguish plastic
			IP Code IP20
			Wiring wires with diameter 0.8÷2.1 mm ²
			AWG 14-18
			Tightening Torque 0.8 N m
			Mounting in compliance with DIN rail standard EN-50022
			Weight about 200 g.
			CERTIFICATIONS
			EMC (for the Industrial Environments)
			Immunity EN 61000-6-2
			Emission EN 61000-6-4
			UKCA (ref S.I. 2016 N°1091)
			Immunity BS EN 61000-6-2
			Emission BS EN 61000-6-4

INSTALLATION INSTRUCTIONS

The device is suitable for fitting to DIN rails in the vertical position.

For optimum operation and long life follow these instructions:

When the devices are installed side by side it may be necessary to separate them by at least 5 mm in the following case:

- If panel temperature exceeds 45°C and power supply voltage 10 Vdc.
Make sure that sufficient air flow is provided for the device avoiding to place raceways or other objects which could obstruct the ventilation slits.
Moreover it is suggested to avoid that devices are mounted above appliances generating heat; their ideal place should be in the lower part of the panel.

Install the device in a place without vibrations.

Moreover it is suggested to avoid routing conductors near power signal cables (motors, induction ovens, inverters etc...) and to use shielded cable for connecting signals.

TERMINALS OVERVIEW

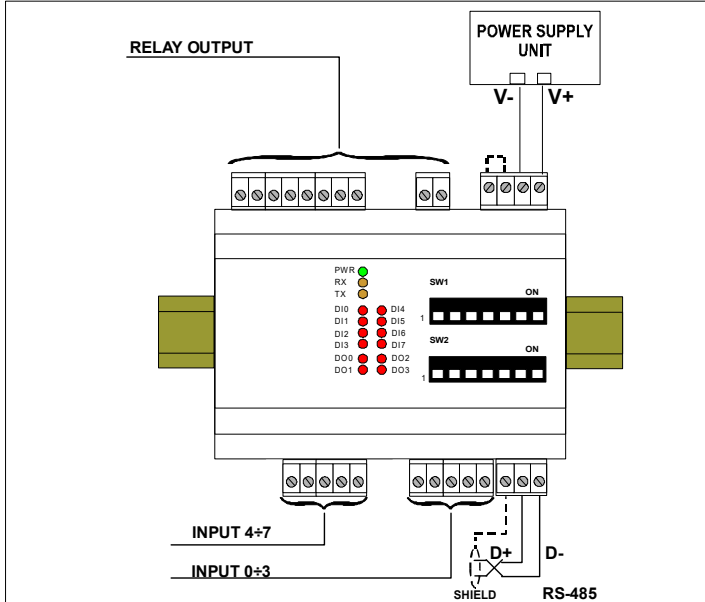

LIGHT SIGNALLING

LED	COLOUR	STATE	DESCRIPTION
PWR	GREEN	ON	Device powered
		OFF	Device not powered
		BLINK	~1 sec. - Watch-Dog alarm condition occurred
RX	ORANGE	BLINK	Stream of data over receiving line of RS-485
		OFF	No data over receiving line of RS-485
TX	ORANGE	BLINK	Stream of data over transmission line of RS-485
		OFF	No data over transmission line of RS-485
DI <i>n</i>	RED	ON	Digital input ON state
		OFF	Digital input OFF state
DO <i>n</i>	RED	ON	Digital output ON state
		OFF	Digital output OFF state

ISOLATION STRUCTURE

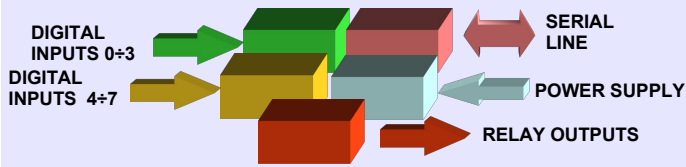

MECHANICAL DIMENSIONS (mm)

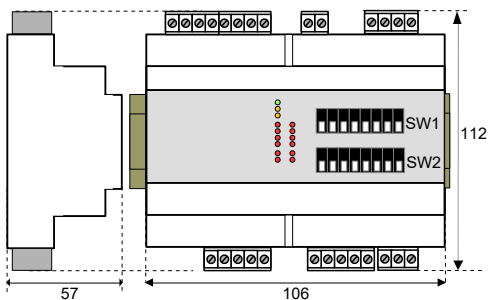

The symbol reported on the product indicates that the product itself must not be considered as a domestic waste. It must be brought to the authorized recycle plant for the recycling of electrical and electronic waste. For more information contact the proper office in the user's city, the service for the waste treatment or the supplier from which the product has been purchased.

WIRING

DIGITAL INPUTS

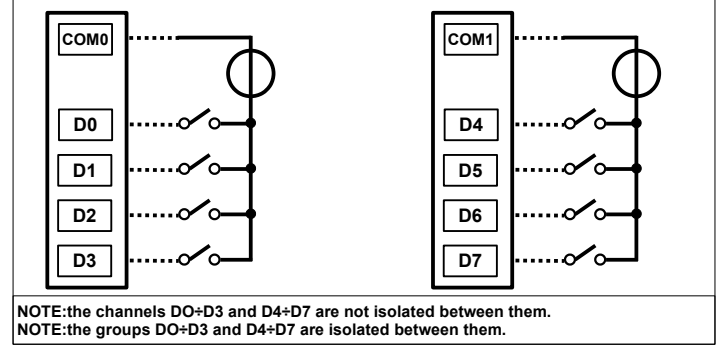

RELAY OUTPUTS

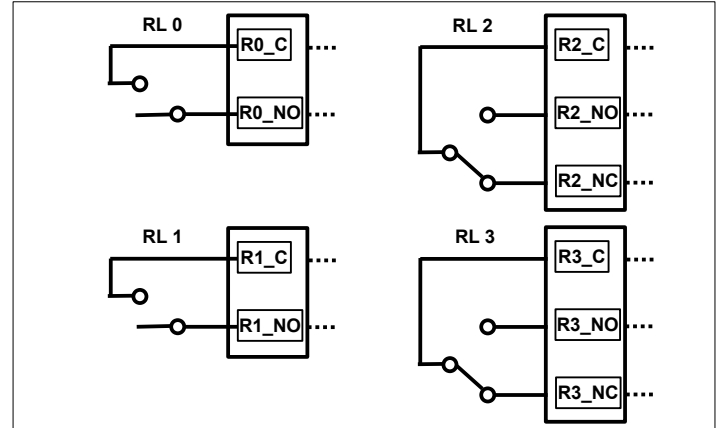

SERIAL LINE RS-485

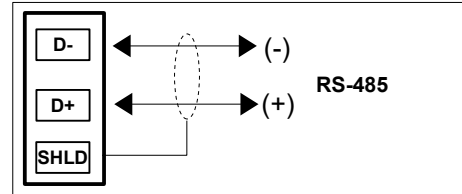

POWER SUPPLY

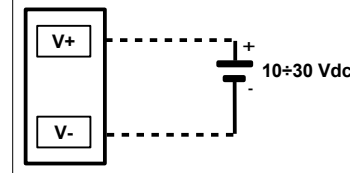

INIT

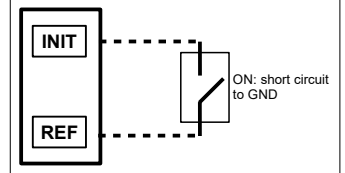

DIP-SWITCHES : TABLES OF CONFIGURATION

Warning: set all the dip-switches in OFF position to access to the device in EEPROM modality (the device will follow all the communication parameters set by software) or INIT. Power-off the device before to change the set of the dip-switches.

TAB.1 Modality settings (Pos.1)

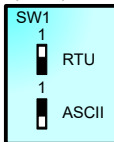

TAB.3 Baud rate settings (Pos.4 LSB; Pos.6 MSB)

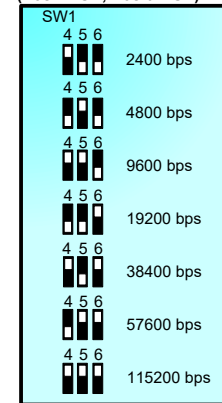

TAB.2 Parity settings (Pos.2 LSB; Pos.3 MSB)

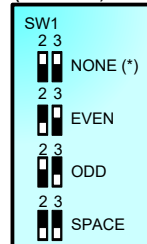

Note (*):

- in Modbus RTU Modality the setting is NONE; number of bit = 8
- in Modbus ASCII Modality the setting is MARK; number of bit = 7

DIP POSITION



HOW TO ORDER

DAT 10130

